

Slide Valves

Flachschieber

Vannes guillotine

Valvole a ghigliottina

VG - VGR - VGM



VG Slide Valves are used to intercept or choke the flow of powders or granules. Their robust structure makes them perfectly suitable for heavy-duty applications in various sectors of application. To ensure maximum protection of the valve, the blade is equipped with a double seal. VG Slide Valves are available with hand wheel or pneumatic or electric actuator (see brochure 040). The powder-coated valves come in silver-grey colour (RAL 7001).

Die Flachschieber der Modellreihe VG sind staubdicht und dank ihrer robusten Bauweise auch für schwere Einsätze in den unterschiedlichsten Industriezweigen geeignet. Zum besseren Schutz des Schiebergehäuses ist eine doppelt wirksame Schieberblechabdichtung vorgesehen. Wahlweise sind die Schieber mit Handrad, elektro-pneumatischem Antrieb oder mit Getriebemotor lieferbar (siehe Kat. Nr. 040). Alle Flachschieber werden in silbergrauem Farbton gemäß RAL 7001 pulverbeschichtet.

Slide Valves - Flachschieber - Vannes guillotine - Valvole a ghigliottina

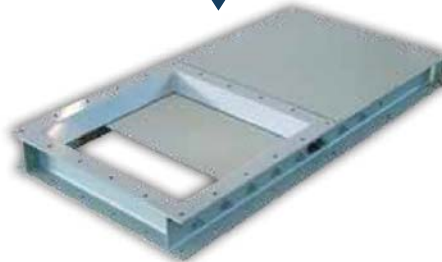

With Hand Wheel or Gear Motor Actuator
Mit Handrad oder Getriebemotor
Avec actionneur manuel ou motoréducteur
Con attuatore manuale o motoriduttore

With Pneumatic Actuator
Mit elektro-pneumatischem Antrieb
Avec actionneur électropneumatique
Con attuatore elettropneumatico

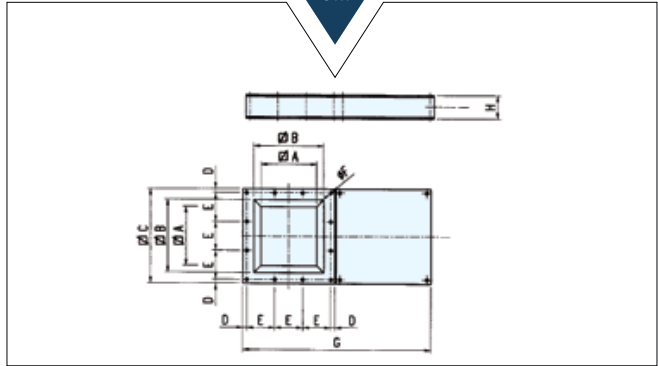
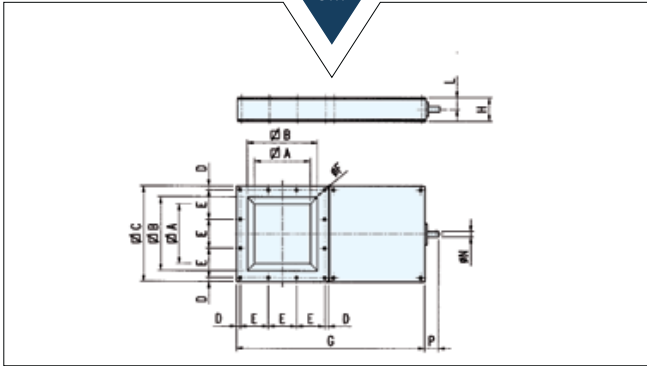

TYPE	A	B	C	D	E	N° E	Ø F	Ø Bolts	G	H	L	Ø N DIN 5482	P	kg	
														VG...V	VG...P
VG 0500..	450	525	653	26.5	120	15	15.5	M 12	1,300	133	35	28 x 25	60	89	87
VG 0600..	550	625	753	26.5	140	15	15.5	M 12	1,500	133	35	28 x 25	60	110	104
VG 0700..	650	725	895	35.0	165	15	15.5	M 12	1,720	133	35	28 x 25	60	135	128
VG 0800..	750	825	995	35.0	185	15	23.0	M 12	1,920	133	35	28 x 25	60	180	172
VG 1000..	950	1,025	1,235	40.0	165	15	18.0	M 12	2,340	133	35	28 x 25	60	240	230

Dimensions in mm

Compatible Actuator - Antriebskompatibilität - Actionneurs compatibles - Attuatori compatibili

Manual Actuator - Handrad - Actionneur manuel - Attuatore manuale



Gear Motor - Getriebemotor Motoréducteur - Motoriduttore

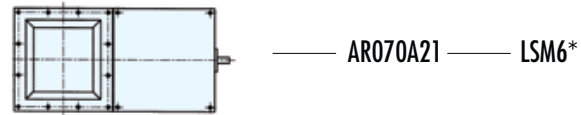

* Signalling Systems Obligatory - Positionsanzeigen unbedingt erforderlich
Systèmes de signalation indispensables - Sistemi indispensabili di segnalazione

Pneumatic Actuator - Elektro-pneumatischer Antrieb - Actionneur électropneumatique - Attuatore elettropneumatico

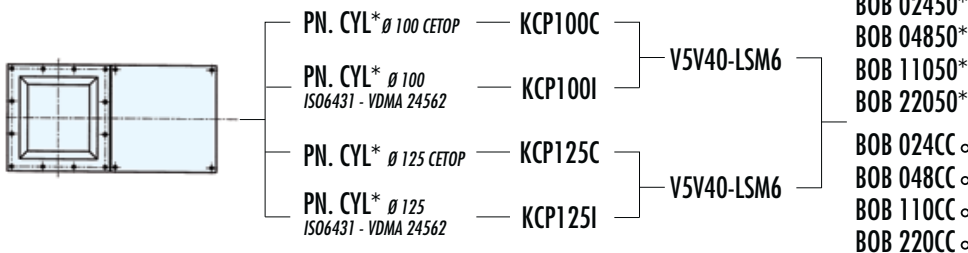

- * Non WAM®
- * Fremdfabrikat
- * Hors fourniture WAM®
- * Non fornitura WAM®
- Alternating Current
- Wechselstrom
- Courant alternatif
- Corrente alternata
- Direct Current
- Gleichstrom
- Courant continu
- Corrente continua

Les vannes VG sont utilisées pour des produits poudreux et granuleux. Elles sont très robustes et bien adaptées aux applications lourdes dans divers secteurs industriels.

Une double protection de la lame permet une moindre usure du corps de la vanne. Les vannes VG existent en version: à actionneur manuel par volant, à actionneur électropneumatique, à actionneur électromécanique.

Les vannes sont livrées peintes à poudre en teinte RAL 7001.

Le valvole VG sono uno strumento utile all'intercettazione e scarico di prodotti in polvere e granulari. Sono realizzate in struttura molto robusta e pertanto anche idonee a servizi gravosi nei più svariati settori di applicazione.

Per assicurare la massima salvaguardia al corpo valvola è stata adottata una doppia protezione sulla lama. Sono fornite a scelta con comando manuale, elettropneumatico e elettromeccanico. (vedi cat. 040) e verniciate a polvere nella tonalità RAL 7001 (grigio-argento).

Rectangular Slide Valves - Rechteckige Flachschieber - Vannes guillotine rectangulaires - Valvole a ghigliottina rettangolari

VGR

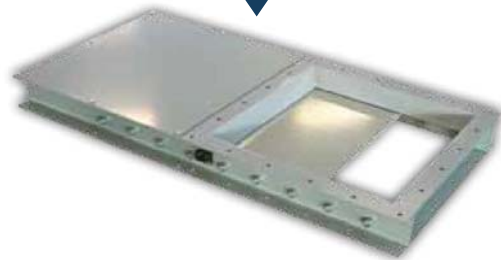

With Manual Lever or Gear Motor Actuator

Mit Handrad oder Getriebemotor

Avec actionneur manuel ou motoréducteur

Con attuatore manuale e motoriduttore

With Pneumatic Actuator

Mit elektropneumatischem Antrieb

Avec actionneur électropneumatique

Con attuatore elettropneumatico

VGR...V

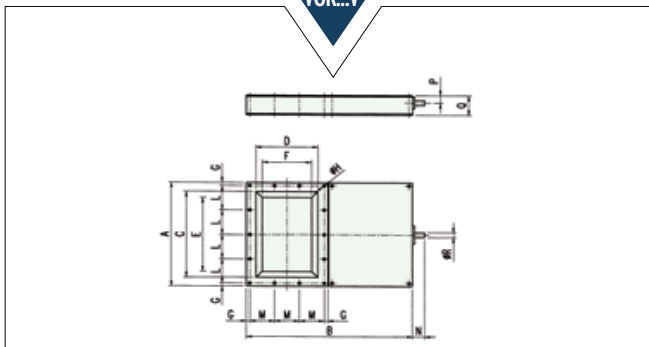

VGR...P

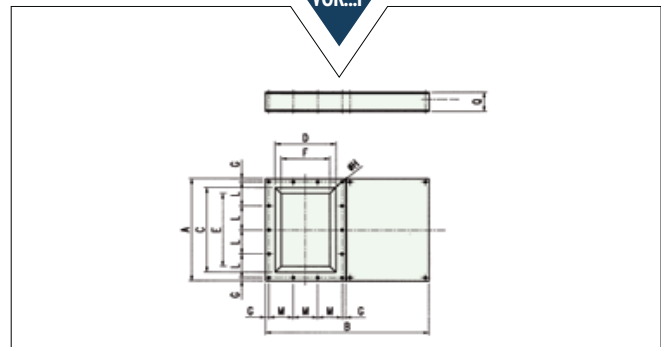

TYPE	A	B	C	D	E	F	G	Ø H	Ø Bolts	L	N° L	M	N° M	N	P	Q	Ø R DIN 5482	kg	
																		VG...V	VG...P
VGR 0150..	346	538	260	175	204	119	15.5	12.5	M 10	105	3	115.0	2	50	72	133	22 x 19	25	23
VGR 0200..	423	638	337	225	281	169	15.5	12.5	M 10	98	4	93.3	3	50	72	133	22 x 19	32	30
VGR 0250..	495	738	409	275	353	219	15.5	12.5	M 10	116	4	110.0	3	50	72	133	22 x 19	39	37
VGR 0300..	590	858	484	325	428	269	23.0	12.5	M 10	136	4	128.3	3	50	72	133	22 x 19	50	47
VGR 0350..	666	958	560	375	504	319	18.0	12.5	M 10	90	7	89.0	5	50	72	133	22 x 19	59	56
VGR 0400..	747	1,089	639	425	565	351	16.5	12.5	M 10	102	7	100.0	5	50	72	133	28 x 25	85	80

Dimensions in mm

Compatible Actuator - Antriebskompatibilität - Actionneurs compatibles - Attuatori compatibili

Manual Lever - Handhebel - Actionneur manuel - Attuatore manuale

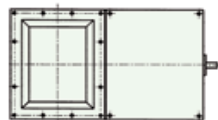

VGR 0150 V.

VGR 0200 V.

VGR 0250 V.

VGR 0300 V.

VGR 0350 V.

VGR 0400 V.

CMV2

CMV4

CMV6

Electropneumatic Actuator - *Elektropneumatischer Antrieb - Actionneur électropneumatique - Attuatore elettropneumatico*

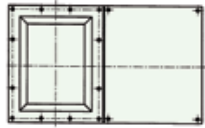

VGR 0150 P.	P.N. CYL Ø 63	13005711A	V5V80-LSM4	BOB 02450* BOB 04850* BOB 11050* BOB 22050*
VGR 0200 P.				
VGR 0250 P.	P.N. CYL Ø 80	13005871A	V5V80-LSM6	
VGR 0300 P.				
VGR 0350 P.	P.N. CYL Ø 100	13005871A	V5V80-LSM6	BOB 024CC ◦ BOB 048CC ◦ BOB 110CC ◦ BOB 220CC ◦
VGR 0400 P.				

Non WAM®
Fremdfabrikat
Hors fourniture WAM®
Non forniture WAM® (Cons. Uff. Comm.)

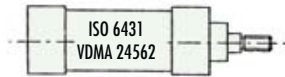

* Non WAM®
* Nicht Wam
* Hors fourniture WAM®
* Non forniture WAM®

• Alternating Current
• Wechselstrom
• Courant alternatif
• Corrente alternata

◦ Direct Current
◦ Gleichstrom
◦ Courant continu
◦ Corrente continua

Gear Motor Drive - *Getriebemotor - Motoréducteur - Motoriduttore*

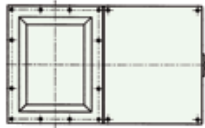

VGR 0150 V.	AR070A11	LSM4*
VGR 0200 V.	AR070A1D	LSM6*
VGR 0250 V.		
VGR 0300 V.		
VGR 0350 V.	AR070A2D	LSM6*
VGR 0400 V.		

* Signalling Systems Obligatory
* Positionsanzeigen unbedingt erforderlich
* Systèmes de signalation indispensables
* Sistemi indispensabili di segnalazione

Push Slide Valves - *Schlagschieber - Vannes guillotine manuelles - Valvola a ghigliottina manuale*

